

FITTING SCHEDULE		
MARK	DIM	DESCRIPTION
A	2"	NPT FITTING W/ 2" SCH 40 MONITOR ACCESS TUBE
F	4"	NPT FILL
F	2"	NPT VENT
F	4"	OPTIONAL NPT FITTING
F	4"	NPT AUTOMATIC TANK GAGE
T	4"	NPT SUBMERSIBLE TURBINE PUMP
UL	2"X3"	UL JACKETED LABEL

Plasteel® Elutron® Jacketed Tank

**50,000 GALLONS CAPACITY
190,000 LITERS**

EMPTY WEIGHT ~ 37,700 LBS / 17,100 KILOGRAM

1. TANK MUST BE UL LISTED AND LABELED JACKETED PER UL STANDARDS 58 AND 1746, PART III.
2. TANK MUST BE INSTALLED PER THE PLASTEEL® TANK MANUFACTURER'S INSTALLATION INSTRUCTIONS.
3. TANK MUST COMPLY WITH THE REQUIREMENTS OF THE AUTHORITY HAVING JURISDICTION.
4. WEIGHTS AND DIMENSIONS ARE APPROXIMATE. CONSULT WITH YOUR PLASTEEL® TANK MANUFACTURER FOR SPECIFIC WEIGHTS AND DIMENSIONS.
5. THREADED CONNECTIONS ARE TYPICAL. PIPING CONTAINMENT SUMP ATTACHMENT COLLARS ARE OPTIONAL. CONSULT WITH YOUR PLASTEEL® TANK MANUFACTURER FOR DETAILS AND OPTIONS.
6. TANK VENT FITTING SIZE MUST COMPLY WITH UL STANDARD 58.

SELECTED FITTINGS FROM ABOVE TABLE

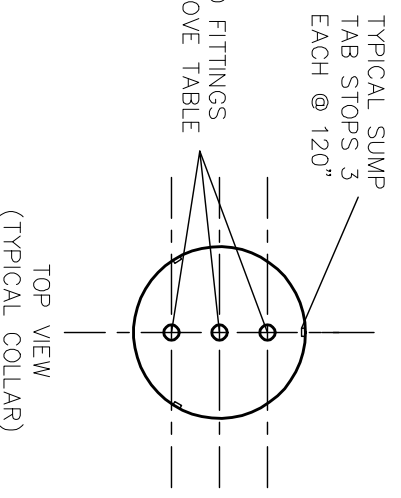

PLASTEEL INTERNATIONAL INC.

2541 STATE STREET, SUITE #206 CARLSBAD, CA 92008	
PHONE: 1-760-729-1093	FAX: 1-760-729-1096
SCALE: NONE	APPROVED BY: _____
DATE: 1-24-07	DRAWN BY: _____

**TYPICAL 50,000 GALLON
PLASTEEL® ELUTRON® JACKETED TANK**