

## Plasteel Composite® Double Wall Tank

**8,000 GALLONS CAPACITY  
30,400 LITERS**

**EMPTY WEIGHT ~ 10,300 LBS / 4,650 KILOGRAM**

1. TANK MUST BE UL LISTED AND LABELED COMPOSITE PER UL STANDARDS 58 AND 1746, PART II.
2. TANK MUST BE INSTALLED PER THE PLASTEEL® TANK MANUFACTURER'S INSTALLATION INSTRUCTIONS.
3. TANK MUST COMPLY WITH THE REQUIREMENTS OF THE AUTHORITY HAVING JURISDICTION.
4. WEIGHTS AND DIMENSIONS ARE APPROXIMATE. CONSULT WITH YOUR PLASTEEL® TANK MANUFACTURER FOR SPECIFIC WEIGHTS AND DIMENSIONS.
5. THREADED CONNECTIONS ARE TYPICAL. PIPING CONTAINMENT SUMP ATTACHMENT COLLARS ARE OPTIONAL. CONSULT WITH YOUR PLASTEEL® TANK MANUFACTURER FOR DETAILS AND OPTIONS.
6. TANK VENT FITTING SIZE MUST COMPLY WITH UL STANDARD 58.

FITTING SCHEDULE		
MARK	DIM	DESCRIPTION
A	2"	NPT FITTING W/ 2" SCH 40 MONITOR ACCESS TUBE
F <sub>F</sub>	4"	NPT FILL
F <sub>V</sub>	2"	NPT VENT
F <sub>O</sub>	4"	OPTIONAL NPT FITTING
F <sub>A</sub>	4"	NPT AUTOMATIC TANK GAGE
T	4"	NPT SUBMERSIBLE TURBINE PUMP
UL	2"X3"	UL COMPOSITE SECONDARY CONTAINMENT LABEL

TYPICAL SUMP  
TAB STOPS 3  
EACH @ 120°

SELECTED FITTINGS  
FROM ABOVE TABLE

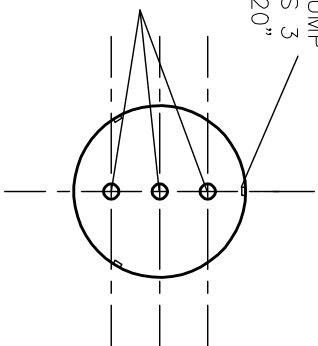

# PLASTEEL

INTERNATIONAL INC.

2541 STATE STREET, SUITE #205

PHONE: 1-700-729-1083

FAX 1-700-729-1086

CARLSBAD, CA 92008

SCALE: NONE

APPROVED BY:

DRAWN BY:

DATE: 1-24-07

TYPICAL 8,000 GALLON

PLASTEEL COMPOSITE® DOUBLE WALL TANK