

Plasteel Composite® Double Wall Tank

**50,000 GALLONS CAPACITY
190,000 LITERS**

EMPTY WEIGHT ~ 61,100 LBS / 27,500 KILOGRAM

1. TANK MUST BE UL LISTED AND LABELED COMPOSITE PER UL STANDARDS 58 AND 1746, PART II.
2. TANK MUST BE INSTALLED PER THE PLASTEEL® TANK MANUFACTURER'S INSTALLATION INSTRUCTIONS.
3. TANK MUST COMPLY WITH THE REQUIREMENTS OF THE AUTHORITY HAVING JURISDICTION.
4. WEIGHTS AND DIMENSIONS ARE APPROXIMATE. CONSULT WITH YOUR PLASTEEL® TANK MANUFACTURER FOR SPECIFIC WEIGHTS AND DIMENSIONS.
5. THREADED CONNECTIONS ARE TYPICAL. PIPING CONTAINMENT SUMP ATTACHMENT COLLARS ARE OPTIONAL. CONSULT WITH YOUR PLASTEEL® TANK MANUFACTURER FOR DETAILS AND OPTIONS.
6. TANK VENT FITTING SIZE MUST COMPLY WITH UL STANDARD 58.

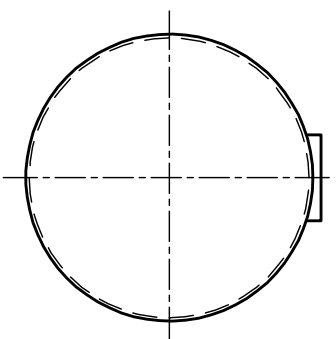

FITTING SCHEDULE		
MARK	DIM	DESCRIPTION
A	2"	NPT FITTING W/ 2" SCH 40 MONITOR ACCESS TUBE
F _F	4"	NPT FILL
F _V	2"	NPT VENT
F _O	4"	OPTIONAL NPT FITTING
F _A	4"	NPT AUTOMATIC TANK GAGE
T	4"	NPT SUBMERSIBLE TURBINE PUMP
UL	2"X3"	UL COMPOSITE SECONDARY CONTAINMENT LABEL

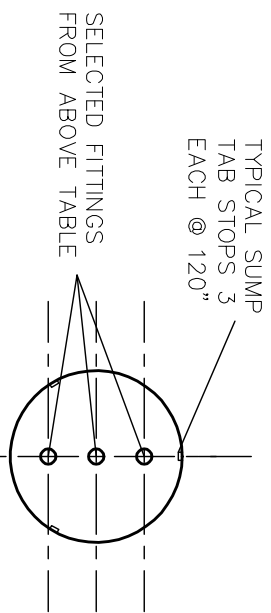

**TOP VIEW
(TYPICAL COLLAR)**

PLASTEEL INTERNATIONAL INC.

2541 STATE STREET, SUITE #206 CARLSBAD, CA 92008
 PHONE: 1-760-729-1083 FAX 1-760-729-1086
 SCALE: NONE APPROVED BY: DRAWN BY:
 DATE: 1-24-07

**TYPICAL 50,000 GALLON
PLASTEEL COMPOSITE® DOUBLE WALL TANK**