

FITTING SCHEDULE			
MARK	DIM	DESCRIPTION	
A	2"	NPT FITTING W/ 2" SCH 40 MONITOR ACCESS TUBE	
F <sub>F</sub>	4"	NPT FILL	
F <sub>V</sub>	2"	NPT VENT	
F <sub>O</sub>	4"	OPTIONAL NPT FITTING	
F <sub>A</sub>	4"	NPT AUTOMATIC TANK GAGE	
T	4"	NPT SUBMERSIBLE TURBINE PUMP	
UL	2"X3"	UL JACKETED LABEL	

**Plasteel® Elutron® 2 Compartment Double Bulkhead Tank**

**20,000 GALLONS CAPACITY 8,000/12,000  
75,708 LITERS 30,283/45,424**

**EMPTY WEIGHT ~ 16,500 LBS / 7484.4 KILOGRAM**

- TANK MUST BE UL LISTED AND LABELED JACKETED PER UL STANDARDS 58 AND 1746, PART III.
- TANK MUST BE INSTALLED PER THE PLASTEEL® TANK MANUFACTURER'S INSTALLATION INSTRUCTIONS.
- TANK MUST COMPLY WITH THE REQUIREMENTS OF THE AUTHORITY HAVING JURISDICTION.
- WEIGHTS AND DIMENSIONS ARE APPROXIMATE. CONSULT WITH YOUR PLASTEEL® TANK MANUFACTURER FOR SPECIFIC WEIGHTS AND DIMENSIONS.
- THREADED CONNECTIONS ARE TYPICAL. CONTAINMENT SUMP ATTACHMENT COLLARS ARE OPTIONAL. CONSULT WITH YOUR PLASTEEL® TANK MANUFACTURER FOR DETAILS AND OPTIONS.
- TANK VENT FITTING SIZE MUST COMPLY WITH UL STANDARD 58.
- MULTIPLE COMPARTMENTS WITH CHOICE OF COMPARTMENT CAPACITIES ARE AVAILABLE. CONSULT YOUR PLASTEEL® TANK MANUFACTURER FOR SPECIFIC DESIGNS.

SELECTED FITTINGS FROM ABOVE TABLE

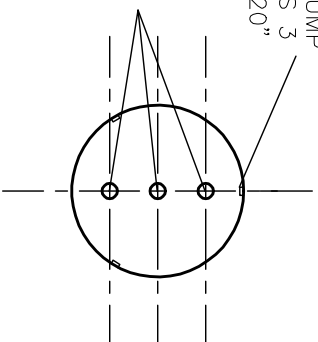

TOP VIEW  
(TYPICAL COLLAR)

**PLASTEEL**  
INTERNATIONAL INC.

2541 STATE STREET, SUITE #205 CARLSBAD, CA 92008  
PHONE: 1-760-729-1083 FAX 1-760-729-1086

SCALE: NONE APPROVED BY: DRAWN BY:

DATE: 1-24-07

**20,000 (COMPARTMENT - 8,000/12,000)**

**PLASTEEL® ELUTRON® JACKETED TANK**